

Electric Termination Press

Features

- Reel fed: RH or LH available
- Tape take-up with replaceable spool
- Guarding interlock for safety
- Good operator visibility
- Halogen work light
- Mini die applicator mounting with spring lever release for quick changeover
- Interchangeable applicators for .100 C/L & .156 C/L connectors
- Available for 2 through 6 position connectors
- 18Ga through 26Ga wire accepted
- Applicator can trim wire up to 3/8" long if required
- Wire scrap collection tray
- Foot pedal controls
- Press may be integrated with wire preparation equipment

For Mas-Con 2 - 6 position connectors

- Connectors supplied on 24" dia. disposable reels
- 10500 (max) circuits per reel (.100)
- 7000 (max) circuits per reel (.156)
- Up to 3600 terminations per hour (operator paced)
- Reduces installed cost

Tape fed connectors
RH or LH available

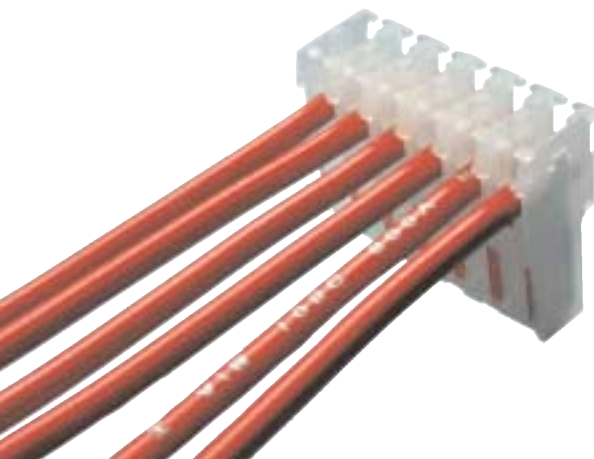

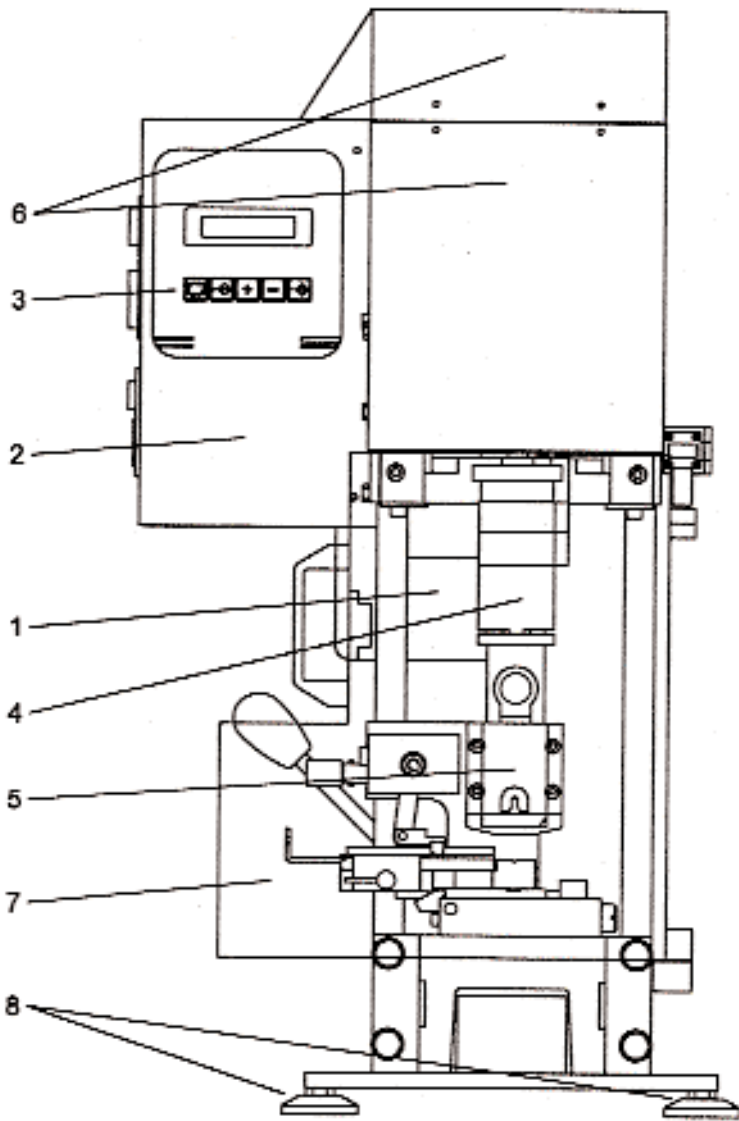

- 1 - Motor
- 2 - Electrical control box
- 3 - Control panel
- 4 - Connecting rod/crank assembly
- 5 - Terminating tool
- 6 - Fixed guard
- 7 - Movable safety guard
- 8 - Feet and adjusters

ITW Pancon
An Illinois Tool Works Company
309 E. Crossroads Parkway
Bolingbrook IL 60440
Phone 1 888 515 2100
Fax 630 972 8900
www.itwpancon.com

Technical Data

Processable Product

- Stranded or solid wire. 18 Ga to 26 Ga

Operating Parameters

- Terminating tool: specific for each type of connector
- Speed and production volume indicator: LCD display
- Machine operation control: pedal
- Stroke: 30mm/40mm
- Press speed is adjustable

Press Information

- Power supply: 220V single phase 50/60 Hz
- Sound volume: less than 50dB

Dimensions

- 45"L x 40"H (including reel) x 20"D

Weight

- 220 lbs.

Ordering Information

Press:

- R to L feed: ETP-MAR
- L to R feed: ETP-MAL

Applicators:

.100 C/L MAS-CON connectors:

- R to L feed: CA1006-R
- L to R feed: CA1006-L

.156 C/L MAS-CON connectors:

- R to L feed: CA1556-R
- L to R feed: CA1556-L

Consult factory for pricing & delivery